

ACV-8 Adjustable Choke Valves

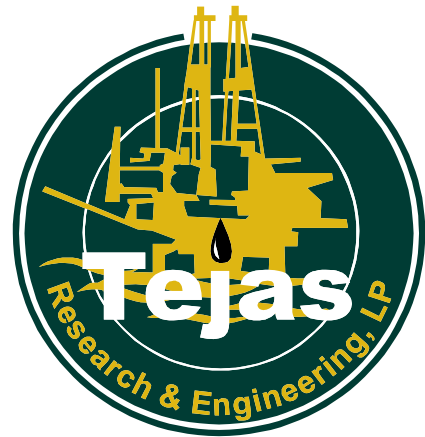

ACV-8 adjustable choke valve with operating detail and valve trim options.

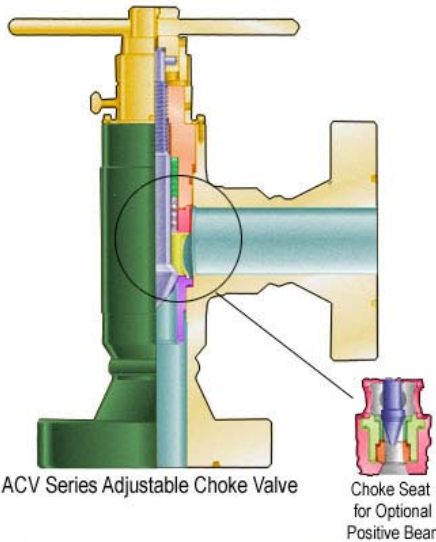

ACV Series Adjustable Choke Valve

Choke Seat for Optional Positive Bean

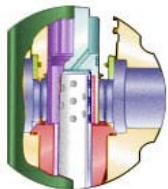

Closed

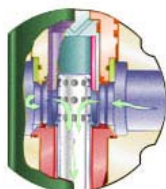

Throttling

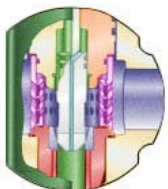

Cavnoise Valve Trim

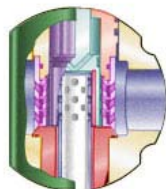

Cavrosion-Cavnoise Valve Trim

ACV-8 adjustable choke valves have wide applications in oil, gas, and water service. Three body sizes allow proper matching of the choke to the expected flow rate. Maximum working pressures to 5000 psi [34,475 kPa] are standard on the ACV-8 series valves. An easily read indicator ring, calibrated in sixty-fourths of an inch, provides accurate flow control, and a spring-loaded Teflon[®] packing design forms a bubble-tight stem seal.

The valve and seat can be removed by hand, without special tools and without removal of the valve body from the line, by simply removing the bonnet.

ACV-8 series valves feature a 2-in. [50.8-mm] maximum port size and offer an optional positive choke seat for high-differential pressures.

Special trim designs

Ported cage and multiple sleeve designs that will provide protection from deterioration caused by cavitation and erosion are available for ACV-8 valves.

Cavitation results from the instantaneous formation of gas bubbles in a fluid. The bubbles are caused by an increase in the fluid velocity at a flow restriction. The increase in fluid velocity is followed by a sudden decrease in fluid pressure to below the vapor pressure of the fluid after

Applications

- Oil, gas, and water service

Benefits

- Cavitation and erosion protection
- Noise suppression
- Internal component replacement without removing valve from service

Features

- Single-element, external-sleeve trim design
- Multiple-ported sleeve design upstream of the flow-throttling element
- Combination valve trim options available



9185 Six Pines Drive | The Woodlands, TX 77380 | T.281.466.8700 | F.281.466.8063

These documents are not controlled and should be considered for reference only. Current information can always be found at WWW.TEJASRE.COM

© Copyright Tejas Research & Engineering, LP 2006. All Rights Reserved

the restriction. As the flow continues downstream of the restriction, the pressure recovers and causes the gas bubbles to implode. The energy released by the implosion results in vibration, noise, and pitting of the internal valve surfaces and the piping.

Erosion damage is caused by particulates or dense fluids flowing at high velocity and impinging on small surface areas. The dissipation of kinetic energy at the trim of most plug and seat, or eclipsing-type choke valves, results in erosion damage.

Special trim designs are available in the following configurations.

Cavrosion valve trim

This single-element, external-sleeve trim design results in reduced cavitation by creating multiple pressure drops and dividing flow.

The Cavrosion valve trim is used in the same choke body as standard trim, and it is designed to afford the same linear flow characteristics as

a standard feature. The valve seat is removed from the high-flow area, and tungsten carbide components are used for throttling the flow.

The tungsten-carbide-coated throat extends below the seat and allows the cavitation to dissipate within the trim.

Cavnoise valve trim

The Cavnoise valve trim design features one, two, or three stationary, multiple-ported sleeves upstream of the flow-throttling element. This design provides the appropriate number of pressure drop stages required for noise suppression and cavitation control. The sleeves can

be used in conjunction with both standard and ported cage trims. Standard sleeve material is precipitation-hardened stainless steel for increased life under severe operating conditions.

Cavrosion-Cavnoise valve trim combination

This combination trim assembly[†] combines the features of cavitation, erosion, and noise-control trims for the most effective protection of the valve internals.

[†]The Cavrosion-Cavnoise valve trim combination is routinely available only on selected sizes. The combination trim is available for any size by special request.

ACV-8 C_v Values Flow Coefficient at Max Setting

Trim Size	C _v Max
1.000 in. [25.4 mm]	30.8
1.500 in. [38.1 mm]	61.5
2.000 in. [50.8 mm]	85.8

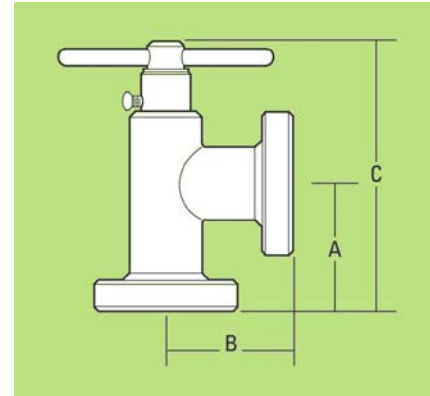

Dimensional data reference figure.

ACV-8 Dimensional Data

Body Style	Max Working Pressure (psi [kPa])	2.500 in. [63.5 mm]			3.000 in. [76.2 mm]			4.000 in. [101.6 mm]		
		A and B (in. [mm])	C (in. [mm])	Approximate Weight (lbm [kg])	A and B (in. [mm])	C (in. [mm])	Approximate Weight (lbm [kg])	A and B (in. [mm])	C (in. [mm])	Approximate Weight (lbm [kg])
Threaded	3000 [20,685]	5.000 [127.0]	15.190 [385.8]	60 [27.2]	5.000 [127.0]	15.190 [385.8]	70 [31.7]	5.440 [138.2]	15.630 [397.0]	80 [36.3]
Socket weld	3600 [24,822]	5.000 [127.0]	15.190 [385.8]	60 [27.2]	5.000 [127.0]	15.190 [385.8]	70 [31.7]	5.440 [138.2]	15.630 [397.0]	80 [36.3]
Butt weld 160	5000 [34,475]	5.000 [127.0]	15.190 [385.8]	60 [27.2]	5.000 [127.0]	15.190 [385.8]	70 [31.7]	5.440 [138.2]	15.630 [397.0]	80 [36.3]
Series 600 RF	1480 [10,205]	6.500 [165.1]	16.690 [423.9]	88 [39.9]	7.000 [177.8]	17.190 [436.6]	106 [48.1]	8.500 [215.9]	18.690 [474.7]	154 [69.8]
Series 600 RJ	1480 [10,205]	6.560 [166.6]	16.750 [425.5]	88 [39.9]	7.070 [179.6]	17.260 [438.4]	106 [48.1]	8.560 [217.4]	18.750 [476.3]	154 [69.8]
Series 900 RF	2220 [15,307]	8.250 [209.6]	18.440 [468.4]	132 [59.9]	7.500 [190.5]	17.690 [449.3]	128 [58.0]	9.000 [228.6]	19.190 [487.4]	182 [82.5]
Series 900 RJ	2220 [15,307]	8.310 [211.1]	18.500 [469.9]	132 [59.9]	7.570 [192.3]	17.760 [451.1]	128 [58.0]	9.060 [230.1]	19.250 [489.0]	182 [82.5]
Series 1500 RF	3705 [25,546]	8.250 [209.6]	18.440 [468.4]	132 [59.9]	9.250 [235.0]	19.440 [493.8]	166 [75.3]	10.360 [263.1]	20.550 [522.0]	218 [98.9]
Series 1500 RJ	3705 [25,546]	8.310 [211.1]	18.500 [469.9]	132 [59.9]	9.320 [236.7]	19.510 [495.6]	166 [75.3]	10.460 [265.7]	21.650 [549.9]	218 [98.9]
Series 2500 RF	5000 [34,475]	10.000 [254.0]	20.190 [512.8]	164 [74.4]	11.370 [288.8]	21.560 [547.6]	258 [117.0]	13.250 [336.6]	23.440 [595.4]	372 [168.7]
Series 2500 RJ	5000 [34,475]	10.130 [257.3]	20.320 [516.1]	164 [74.4]	11.500 [292.1]	21.690 [550.9]	258 [117.0]	13.400 [340.4]	23.590 [599.2]	372 [168.7]
API 2000	2000 [13,790]	6.560 [166.6]	16.750 [425.5]	88 [39.9]	7.060 [179.3]	17.250 [438.2]	106 [48.1]	8.560 [217.4]	18.750 [476.3]	154 [69.8]
API 3000	3000 [20,685]	8.310 [211.1]	18.500 [469.9]	132 [59.9]	7.570 [192.3]	17.760 [451.1]	128 [58.0]	9.060 [230.1]	19.250 [489.0]	182 [82.5]
API 5000	5000 [34,475]	8.310 [211.1]	18.500 [469.9]	132 [59.9]	9.310 [236.5]	19.500 [495.3]	166 [75.3]	10.810 [274.6]	21.000 [533.4]	218 [98.9]